

Vane wheel probe ZS25 for flow measurement of gases and liquids with integrated, configurable transducer UFA in Ex-d housing

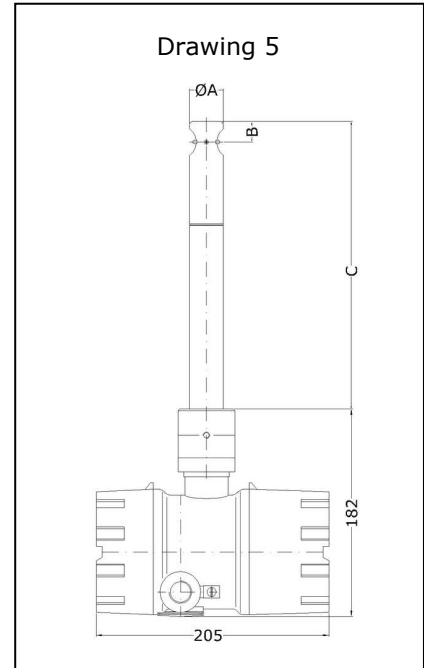

Vane wheel flow probe ZS25
(Dimensions see Page 3)

Measurable variables

- actual flow velocity v [m/s] in air/gases
- (actual) flow rate [m³/h] in air/gases and water/liquids
- conversion to standard velocity/standard volume flow by entering working pressure and temperature parameters

Measuring range

- 0.3 ... 120 m/s air/gases
- 0.03 ... 10 m/s water/liquids

Functional principle

- vane wheel flow sensor
- sensing the vane rotation; non-contact by means of inductive proximity switch

Medium

- air, gas mixtures and clean gases
- water, liquids with viscosities of up to 200 cSt

Design

- insertion probe with Ex-d housing

Examples of application

- flow measurement e.g. of air, exhaust gas, process gas
- in processes with varying and/or unknown gas compositions
- flow monitoring in pharmaceutical installations
- monitoring inertisation processes
- measurement of flammable liquids
- measuring in non-conducting liquids such as ultra pure water, for example in the semiconductor industry

Advantages

- accurate measured values even in varying and/or unknown gas compositions

- compact design with optional on-site display in Ex-application
- application in category 1 (zones 0 and 20), transducer housing approved for Category 2 (zones 1 and 21)
- no external isolation/supply unit necessary

Humidity in the sample gas

- relative gas humidity of less than 100 % has no impact on the measurement uncertainty

Particles in the medium

- can cause restriction in the fatigue strength of the vane wheel set

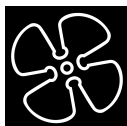

Model designation (example)

ZS25/25	-350	GF	E	350	p10	Ex-d	ZG5
(1)	(2)	(3)	(4)	(5)	(6)	(7)	(8)

Basic types

Type	Article No.
'stainless steel 100 °C'	
ZS25/25- 250 GFE/100/p10/ZG5 Ex-d	b002/255
ZS25/25- 350 GFE/100/p10/ZG5 Ex-d	b002/256
ZS25/25- 450 GFE/100/p10/ZG5 Ex-d	b002/257
ZS25/25- 550 GFE/100/p10/ZG5 Ex-d	b002/258
ZS25/25- 650 GFE/100/p10/ZG5 Ex-d	b002/259
'stainless steel 260 °C'	
ZS25/25- 250 GFE/260/p10/ZG5 Ex-d	b002/260
ZS25/25- 350 GFE/260/p10/ZG5 Ex-d	b002/261
ZS25/25- 450 GFE/260/p10/ZG5 Ex-d	b002/262
ZS25/25- 550 GFE/260/p10/ZG5 Ex-d	b002/263
ZS25/25- 650 GFE/260/p10/ZG5 Ex-d	b002/264
'stainless steel 370 °C'	
ZS25/25- 250 GFE/370/p10/ZG5 Ex-d	b002/265
ZS25/25- 350 GFE/370/p10/ZG5 Ex-d	b002/266
ZS25/25- 450 GFE/370/p10/ZG5 Ex-d	b002/267
ZS25/25- 550 GFE/370/p10/ZG5 Ex-d	b002/268
ZS25/25- 650 GFE/370/p10/ZG5 Ex-d	b002/269
'stainless steel 500 °C'	
ZS25/25- 250 GFE/500/p10/ZG5 Ex-d	b002/270
ZS25/25- 350 GFE/500/p10/ZG5 Ex-d	b002/271
ZS25/25- 450 GFE/500/p10/ZG5 Ex-d	b002/272
ZS25/25- 550 GFE/500/p10/ZG5 Ex-d	b002/273
ZS25/25- 650 GFE/500/p10/ZG5 Ex-d	b002/274
'titanium 100 °C'	
ZS25/25- 250 GFT/100/p10/ZG5 Ex-d	b002/280
ZS25/25- 350 GFT/100/p10/ZG5 Ex-d	b002/281
ZS25/25- 450 GFT/100/p10/ZG5 Ex-d	b002/282
ZS25/25- 550 GFT/100/p10/ZG5 Ex-d	b002/283
ZS25/25- 650 GFT/100/p10/ZG5 Ex-d	b002/284
'titanium 260 °C'	
ZS25/25- 250 GFT/260/p10/ZG5 Ex-d	b002/285
ZS25/25- 350 GFT/260/p10/ZG5 Ex-d	b002/286
ZS25/25- 450 GFT/260/p10/ZG5 Ex-d	b002/287
ZS25/25- 550 GFT/260/p10/ZG5 Ex-d	b002/288
ZS25/25- 650 GFT/260/p10/ZG5 Ex-d	b002/289

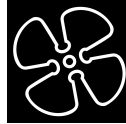

Basic types (cont.)

Type	Article No.
'titanium 370 °C'	
ZS25/25- 250 GFT/370/p10/ZG5 Ex-d	b002/290
ZS25/25- 350 GFT/370/p10/ZG5 Ex-d	b002/291
ZS25/25- 450 GFT/370/p10/ZG5 Ex-d	b002/292
ZS25/25- 550 GFT/370/p10/ZG5 Ex-d	b002/293
ZS25/25- 650 GFT/370/p10/ZG5 Ex-d	b002/294

(1) Sensor type / diameter

Vane wheel flow sensor ZS25 with sensor Ø 25 mm and shaft Ø 25 mm

(2) Sensor length - dimension C (see Drawing Page 1)

250 / 350 / 450 / 550 / 650 mm

(3) Medium

... GF ... air / gases and water/liquids

(4) Materials in contact with the medium

Design	Material
... E ... stainless steel	stainless steel 1.4404 / AISI 316L, ceramics Al ₂ O ₃ 99.9 %, design '100 °C' and '260 °C': PTFE seal design '370 °C' and '500 °C': pure graphite seal
... T ... titanium	titanium 3.7035 (Grade 2), ceramics Al ₂ O ₃ 99.9 %, design '100 °C' and '260 °C': PTFE seal design '370 °C' and '500 °C': pure graphite seal

(5) Permissible temperature of the medium

Design	Temperature
... 100 ...	-20 ... +100 °C (constant)
... 260 ...	-40 ... +260 °C (constant), -40 ... +300 °C (short-term)
... 370 ...	-40 ... +370 °C (constant), -40 ... +400 °C (short-term)
... 500 ...	-40 ... +500 °C (constant), -40 ... +550 °C (short-term)

Ambient -20 ... +50 °C without 'LCD display' option

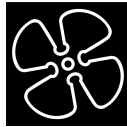

(6) Max. working pressure / type of protection (sensor)

up to 10 bar / 1 MPa kPa overpressure
greater working pressure on request
type of protection IP68

(7) Ex-protection

for gas : Ⓜ II 1/2 G Ex ia/d e [ia] IIC T6 Ga/Gb and
for dust : Ⓜ II 1/2 D Ex ia/tb IIIC TX Da/Db
sensor for application in Category 1 (Ex-Zone 0 or 20),
transducer housing for application in Category 2 (Ex-Zone 1 or 21)

(8) Design

as in Drawing 5 (see Page 1)

dimensions	A Ø 25 mm	B 13.9 mm	C 250/350/450/550/650 mm
------------	-----------	-----------	--------------------------

Measuring range / vane wheel type

Measuring range air/gases*	Measuring range water/liquids**	Vane wheel type			Article No.
with 'stainless steel' probe					
0.4 ... 20 m/s	0.04 ... 7.5 m/s	mn	20	E	v_mn20GFE
0.5 ... 40 m/s	0.05 ... 10 m/s	mn	40	E	v_mn40GFE
1.0 ... 80 m/s	0.08 ... 10 m/s	mn	80	E	v_mn80GFE
1.4 ... 120 m/s	0.10 ... 10 m/s	mn	120	E	v_mn120GFE
with 'titanium' probe					
0.3 ... 20 m/s	0.03 ... 7.5 m/s	mn	20	T	v_mn20GFT
0.4 ... 40 m/s	0.04 ... 10 m/s	mn	40	T	v_mn40GFT
0.8 ... 80 m/s	0.06 ... 10 m/s	mn	80	T	v_mn80GFT
1.2 ... 120 m/s	0.08 ... 10 m/s	mn	120	T	v_mn120GFT

Measurement uncertainty	for air/gases and water	: < 1.5 % of measured value + 0.5 % of terminal value
-------------------------	-------------------------	---

Repeatability	for air/gases and water	: ±(0.05 % of terminal value + 0.02 m/s)
---------------	-------------------------	--

* with an air/gas density of approx. 1.2 kg/m³

** the specified measuring range for application in liquids is usable provided that cavitation does not arise around the vane wheel.

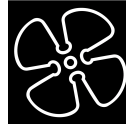

Ex-d transducer housing

Dimensions	outside diameter/length/height: approx. 110/205/182 mm
Material	die-cast aluminium max. 0.5 % Mg, coated housing
Type of protection	IP68, IEC 529 and EN 60 529
Connection	bush for shielded cables with outside diameter 5 ... 9 mm, contacting of the overall shielding on the earth terminal in the housing; connection via screw-type terminals Ex-e for wires with cross-section 0.14 – 1.5 mm ²
Alignment to the sensor	connection housing rotatable by approx. 350 ° and lockable
Set up	dual chamber system, consisting of 1) electronics in Ex-d protection (pressure-resistant casing) and 2) connection area in Ex-e protection (increased safety) with terminal block and bush

Electromagnetic Compatibility (EMC)

according to EN 61 000-6-2 / IEC77

Mounting attitude

any

Transducer UFA, integrated in the connection housing

Analog output flow	4 ... 20 mA working resistance max. 500 Ohm, with HART [®] modem adapter: resistance min. 250 Ohm, max. 500 Ohm
Output limit value or quantity pulse	potential-free relay contact (normally open contact), max. 300 mA / 27 VDC
Communication port	HART [®] , via modem adapter for PC connection and PC software UCOM (see Accessories)
Self-monitoring	output signals are electrically isolated from the power supply parameter settings, sensor interface; in the case of error: analog output less than 3.6 mA
Power supply	24 V DC (20 ... 27 V DC)
Power consumption	less than 5 W
Setting parameter (selection depending on parameter set)	analog output, time constant, profile factor, tube inside diameter, limit value or quantity pulse (quality rating adjustable), switch-over actual/standard flow with setting parameters 'working pressure' and 'working temperature'

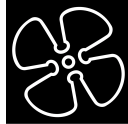

Accessories (optional)		
	Description	Article No.
LCD display	1st line: 'instantaneous value': flow rate or flow velocity 2nd line: 'counter' or 'error code'; 2 x 16-digit, character height 5.5 mm, working temperature range -20 ... +50 °C display rotatable in 90 °-stages on removing the window of the Ex-d housing	a010/520
Calibration certificate v/FA	6 standard calibration values, (see Data Sheet U183)	klbneu
HART® modem adapter	for changing the setting parameter, for PC-USB connection	a010/101
PC software UCOM	for configuring the transducer via RS232	a010/052



Ex-d transducer housing with optional LCD display



Accessories (cont.)

	Description	Article No.
Direction indicator RZ25	for recognition of the direction of flow and insertion depth, adjustable, for probes and probe extensions with Ø 25 mm	b099/953
Probe guide piece SFB 25 E-70 / F-DN50 PN16 ZG1 for 550 °C as in Drawing 1	for any repeated positioning with marginal excess pressure (max. 2 bar/ 200 kPa) / low pressure, working temperature range -40 ... +550 °C, through hole 25 mm, for connection to flange nipples or ball valves with flange, probe attachment with clamping bush, materials: stainless steel, graphite flange DN50 PN16 in conformity with DIN, installation length L 70 mm	b004/110
Probe guide piece SFK 25 E-100 / G 2" ZG2 with clamping yoke as in Drawing 2	for any repeated positioning even with higher excess pressure (max. 10 bar/1 MPa) / low pressure, through hole 25 mm, for connection to threaded socket or ball valve with inside thread G 2", working temperature range -20 ... +240 °C, installation length 100 mm, materials: stainless steel, VITON®-lip seal, incl. hook spanner and hexagon screwdriver	b004/210
Probe guide piece SFB 25 E-54 / G 1 1/4" ZG5 with bushing as in Drawing 5	for any repeated positioning with marginal excess pressure (max. 2 bar/ 200 kPa) / low pressure, through hole 25 mm, for connection to threaded socket or ball valve with inside thread G 1 1/4", working temperature range -20 ... +240 °C, installation length 54 mm, materials: stainless steel, VITON®, PTFE clamping bush	b004/510

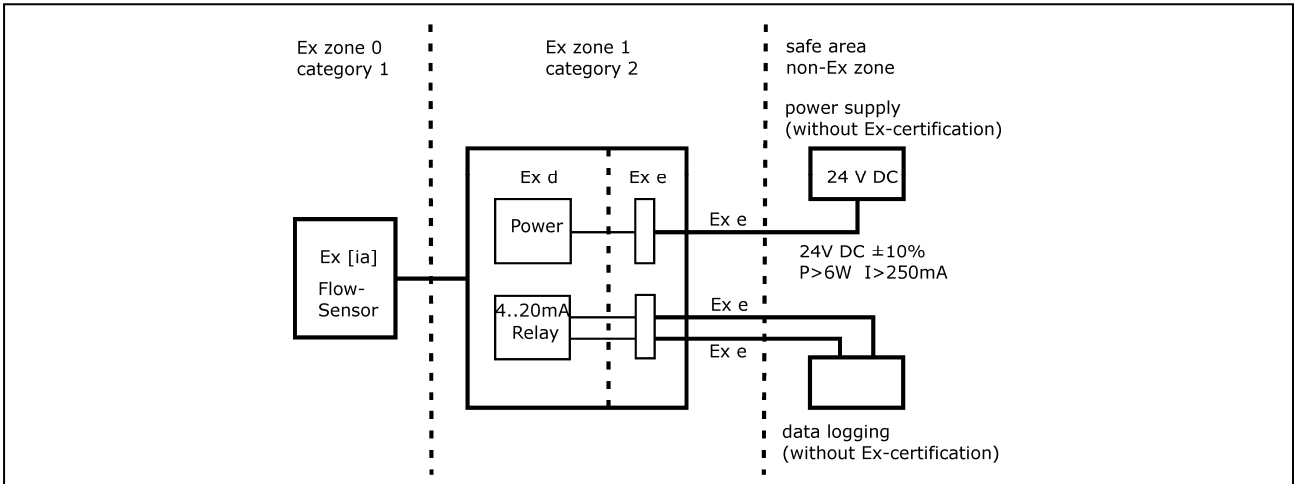
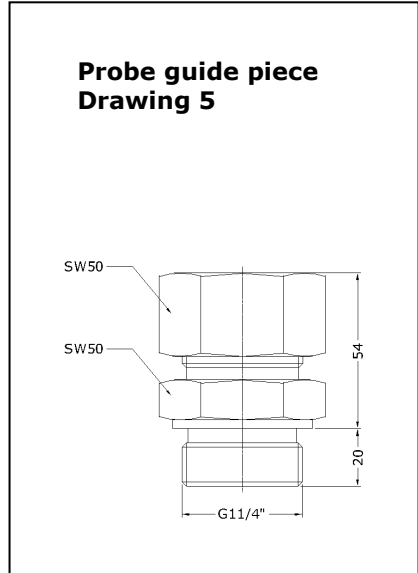
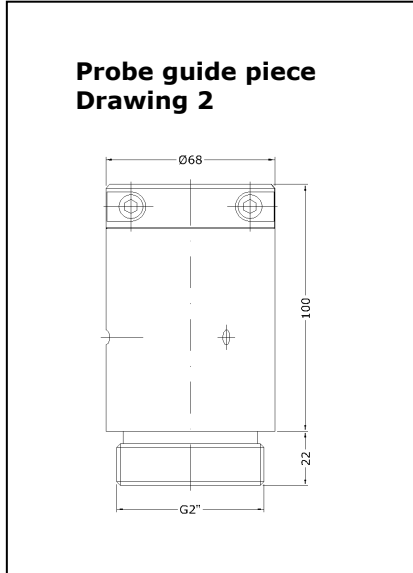
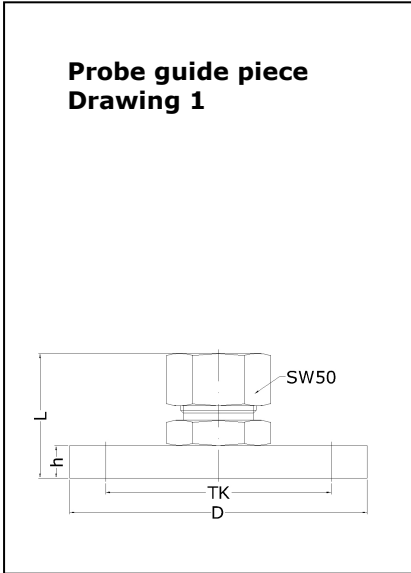
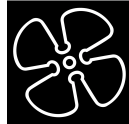

Diagram of Ex-Zones